

BENZ SPECIFICATION

(W221 2010 model)

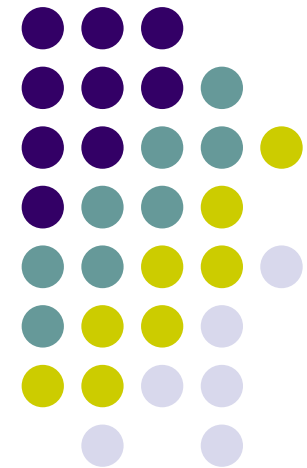

- . MODEL: QVL-MB10-RND-V1
- . Product Code : MB10-RND-V1-1001-000



INDEX



- . 2010 BENZ Feature	3
- . Precaution	4
- . Main Spec.	5
- . Switching Mode through CAN	6
- . System Composition	7
- . Outline Dimension.....	8
- . Connector Pin Assignment	9
- . DIP SW Setting	11
- . How to use Remote control	12
- . OSD (On Screen Display)	13
- . How to use parking guide line.....	19
- . Product Composition	21
- . Installation Structure	22
- . Installation Guide	23
- . FAQ	27

- 2010 BENZ Feature



- More convenience to install with plug & play (HSD cable offered)
- Possible to move the displayed position of DVD, Navi
- NAVI Model Selection (WQVGA, WVGA)
- +12V Output (From Navi, AV1 , Rear (For Rear Camera power)

Precaution



- You must keep the car key taken off from the car while you work this and finally, connect power of the interface.
- When to connect the interface cable, you must keep the power cable taken off.
- You must work this at the environment without any static electricity or damages.
- All of process on this installation should be done by professionals.
- You must not break the labels attached on the board, if it's broken, no warranty.
- When you receive this package you have to check whether there's any parts not included and you have to contact us right away.
- Our repair service do not accept any problems caused by user's any fault or carelessness.

Main Spec.



1. Input Spec. (MULTI VIDEO INTERFACE)

- 1 x Analog R,G,B (Sync on Green)
- 1 x CVBS(NTST & PAL Auto Detect) Input. (Rear camera source)
- 3 x CVBS(NTST & PAL Auto Detect) Input. (A/V source)
- 1 x LCD Input (Car system Input)

2. Output Spec.

- 1 x CVBS OUTPUT (Video Out for installing Headrest monitor)
- 1 x Audio OUTPUT
- 1 x LCD OUTPUT(LCD Operation)

3. Power Spec.

- Input Power : 18V
- Consumption Power : 12WATT, Max

4. Mode Switching

- Possible to skip AV source while switching Mode (AV source) by DIP S/W (Refer to the DIP S/W page)
- By Remote Controller
- By Toggle S/W
- By Original button of the car through CAN (W221(8") : NAVI Button)

Switching Mode through CAN



After wiring CAN of the car with offered CAN cable, you can switch A/V mode by the Factory button as below. Refer to the next page for wiring)



2010 W221 model 8" (NEW S-Class) :
Switching Mode by "Navi/Tel" Button like the left picture

Black : CAN LOW(Green)

Black+White: CAN HIGH(Green+Brown)

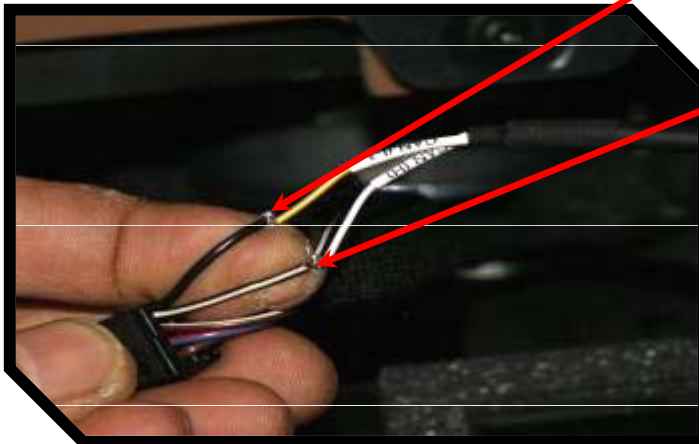

- Connect a Green+Brown wire from power cable to a black+white wire from Car (CAN HIGH) and a Green wire to a Black wire from Car (CAN LOW)
- The CAN wires are behind of LCD.

* The color of CAN wires coming from the car can be different by each countries that the car import or any other circumstances.

System Composition

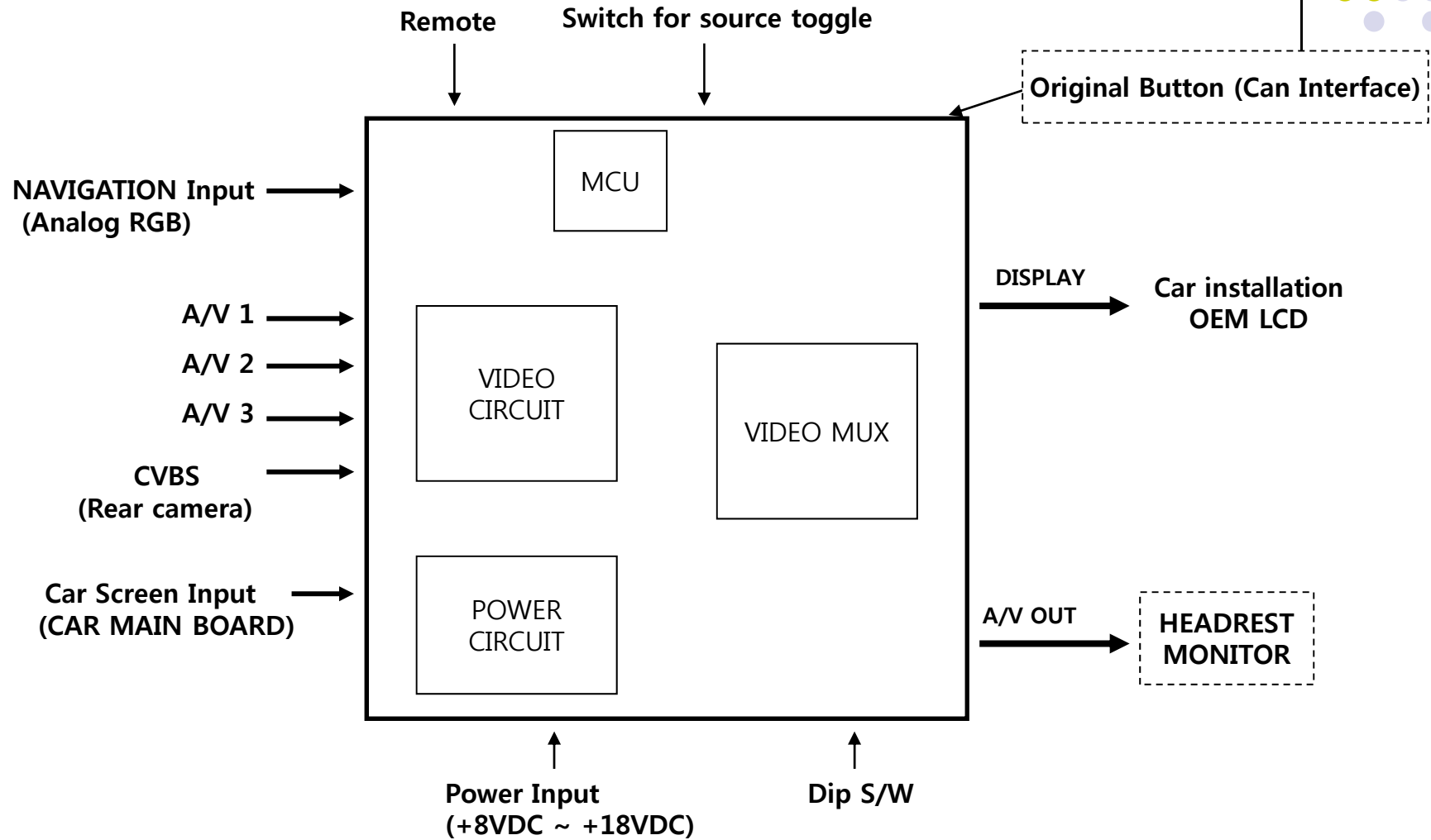

Outline Dimension



153mm * 90mm * 22mm



Connector Pin Assignment

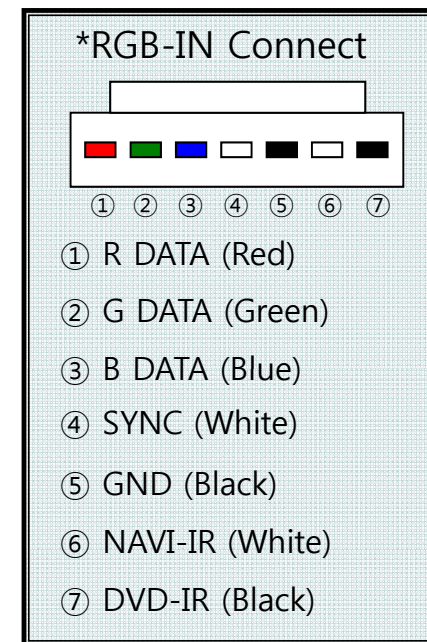
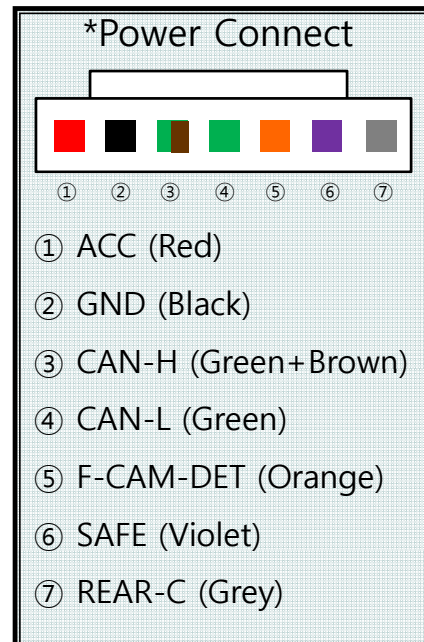
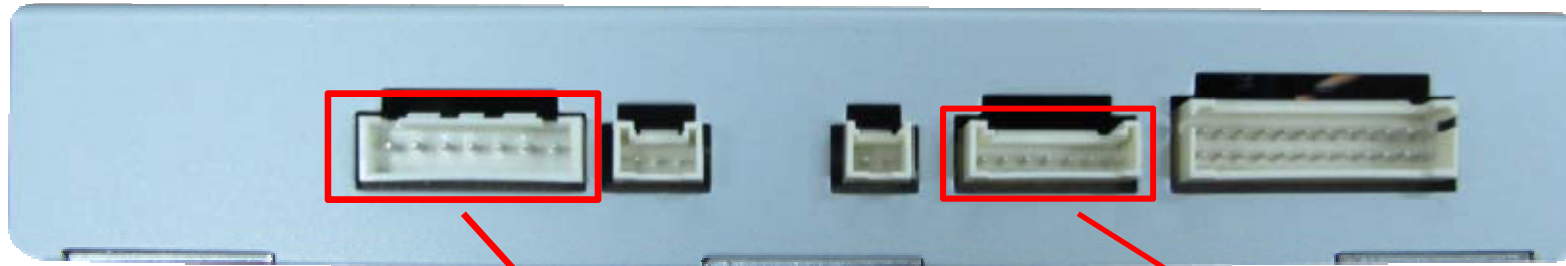

※ F-CAM-DET : Not Used
 NAVI-IR : Not Used
 DVD-IR : Not Used

Connector Pin Assignment



* Power Cable

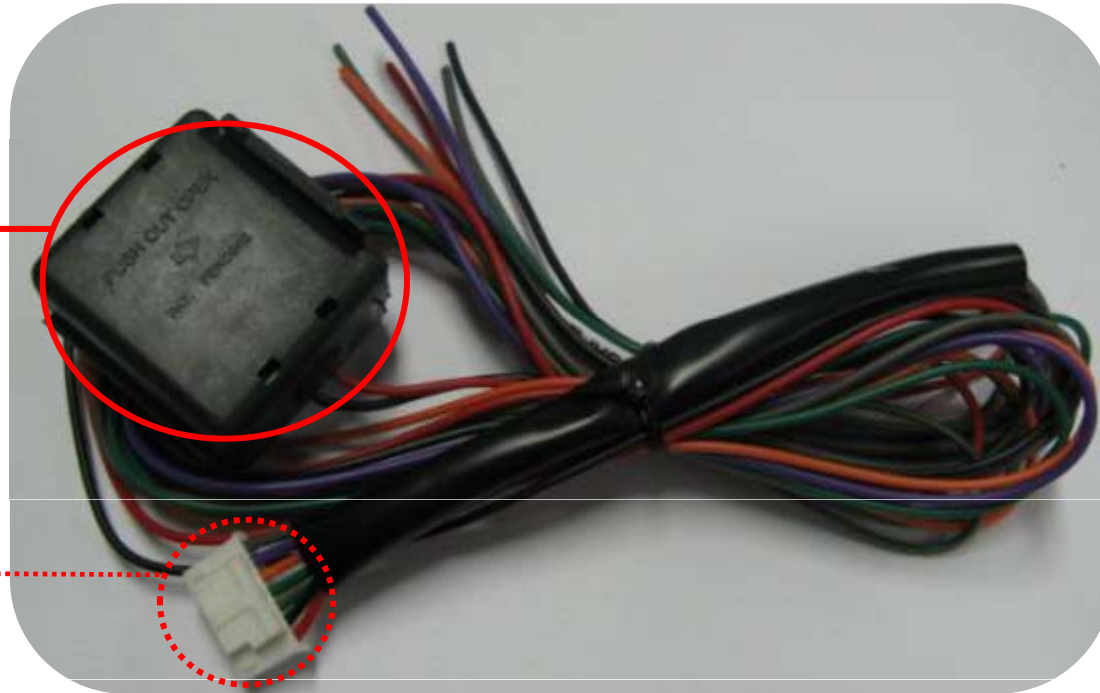

**FILTER
& FUSE BOX**

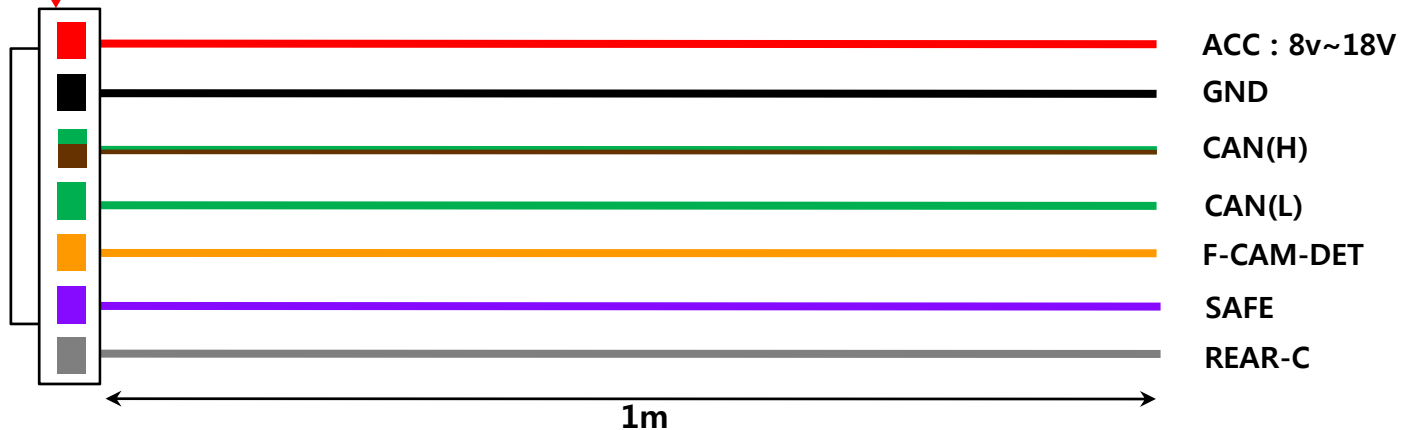

-DIP SW Setting



#PIN	FUNCTION	DIP S/W Selection
1	RGB INPUT MUTE	ON : Skipping RGB Mode OFF : RGB Display
2	A/V 1 MUTE	ON : Skipping A/V 1 OFF : A/V1 Display
3	A/V 2 MUTE	ON : Skipping A/V 2 OFF : A/V2 Display
4	A/V 3 MUTE	ON : Skipping A/V 3 OFF : A/V3 Display
5	N.C	
6	N.C	
7	Rear Mode	ON : External Rear Camera OFF : OEM Rear Camera
8	OEM Navi Mute	ON : In case of OEM NAVI installed OFF : In case of OEM NAVI not installed

※DIP S/W Use Example

- Use Input Mode : A/V3(DVD), Navigation (RGB)
- Rear Camera : When to be installed on CVBS 4
- When original Navi is not installed

- ▷ DIP S/W : 1 → OFF
- ▷ DIP S/W : 2,3 → ON
(INPUT MODE SKIP)
- ▷ DIP S/W : 4 → OFF (enable A/V3)
- ▷ DIP S/W : 5 → OFF
- ▷ DIP S/W : 6 → OFF
- ▷ DIP S/W : 7 → ON (enable CVBS4)
- ▷ DIP S/W : 8 → OFF

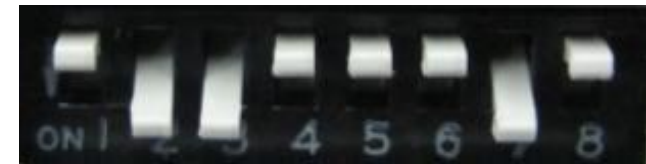

※ ON : DOWN, OFF : UP

How to use remote



Dimension : 85 * 40 * 8 (mm)



POWER&PIP : N.C

MENU : OSD MENU

OK : Selection

▲ : Up

▼ : Down

◀ : Left

▶ : Right

***FACTORY MODE (Interface setting for **installer**)**

: Operated by pressing ▲ → ▼ → ▲ → MENU or press ◀ more than 5sec of remote

-OSD(On Screen Display)



• Analog RGB Mode

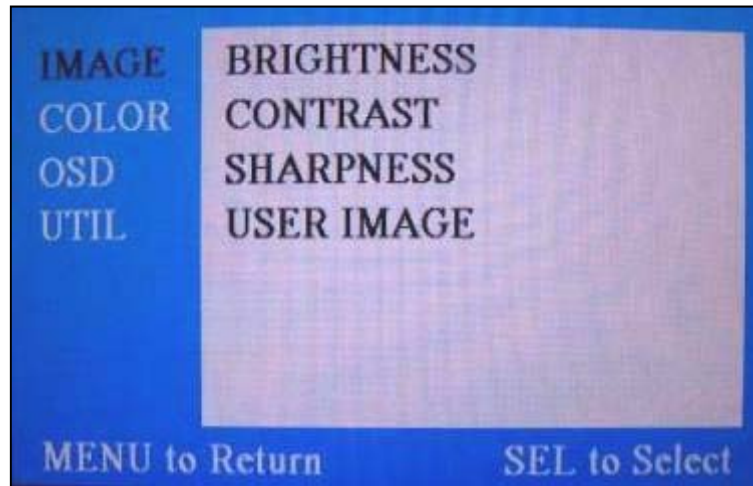

• Video Mode



IMAGE Menu

- BRIGHTNESS: Adjust brightness of the screen.
- CONTRAST: Adjust distinction (Image noise clearness).
- SATURATION: Adjust the saturation the picture.
- HUE: Adjust the display hue adjustment of the screen.
- SHARPNESS: Adjust the sharpen or soften the picture.
- USER IMAGE : Select color of screen (only four types)

OSD(On Screen Display)



- Analog RGB Mode

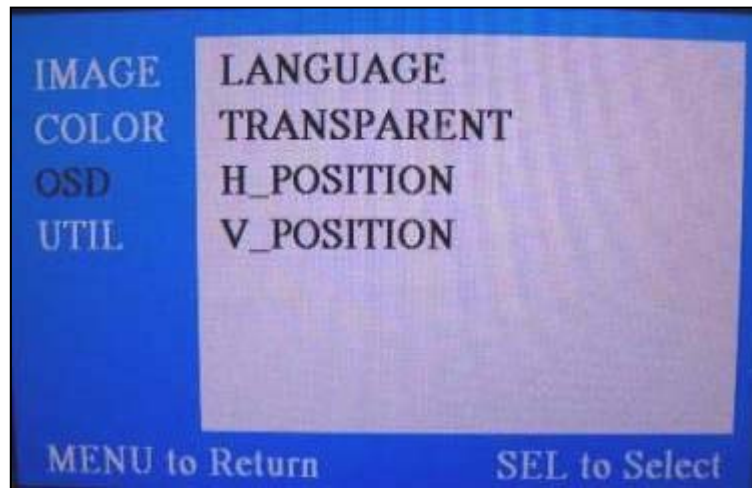

- Video Mode

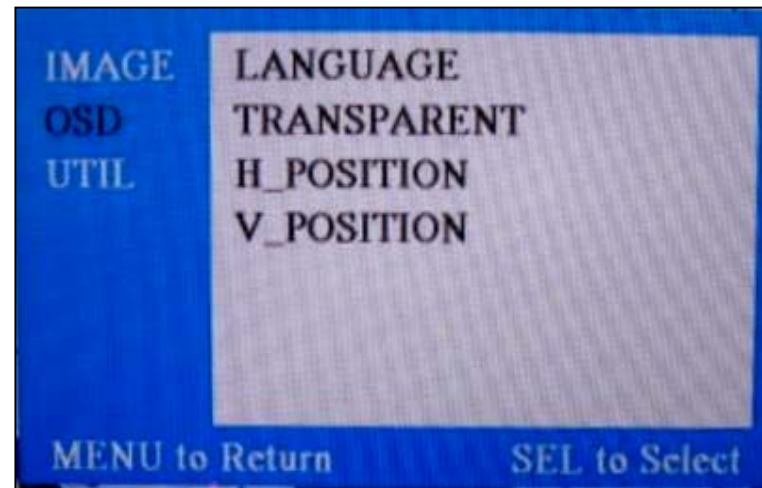

OSD Menu

- LANGUAGE: OSD language and appearance can be changed.
- TRANSPARENT: You can select the OSD background to be opaque or translucent.
- H_POSITION : Move the position of AV sources to Left, Right
- V_POSITION : Move the position of AV sources to Up, Down

OSD(On Screen Display)



- Analog RGB Mode

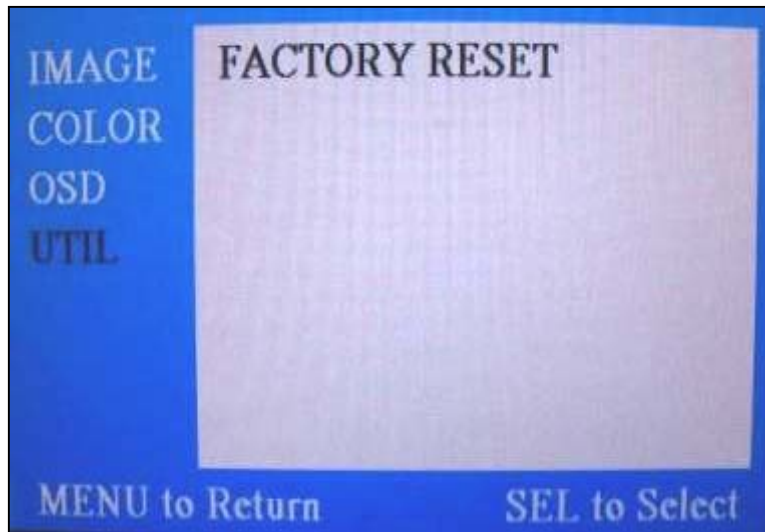

- Video Mode

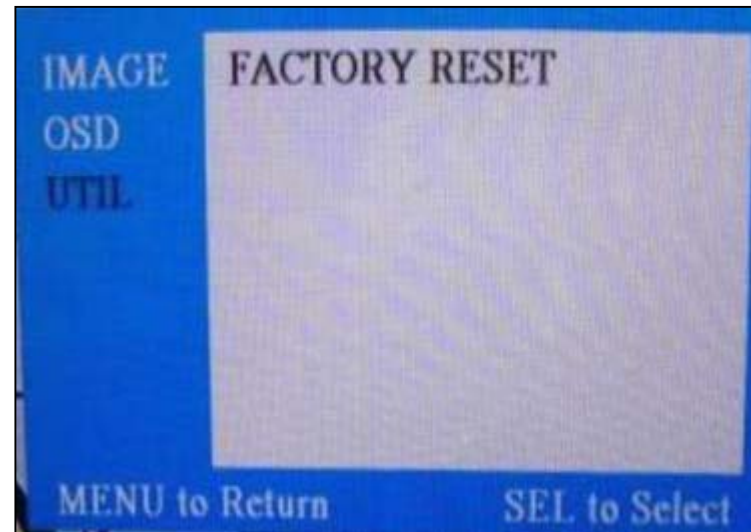

UTIL Menu

- FACTORY RESET : Initializing of all values of OSD setting
(Impossible to reset of screen position, only possible for functions in OSD)

OSD(On Screen Display)



- **Factory Mode** - Operated by pressing ▲ → ▼ → ▲ → MENU or press ◀ more than 5sec of remote

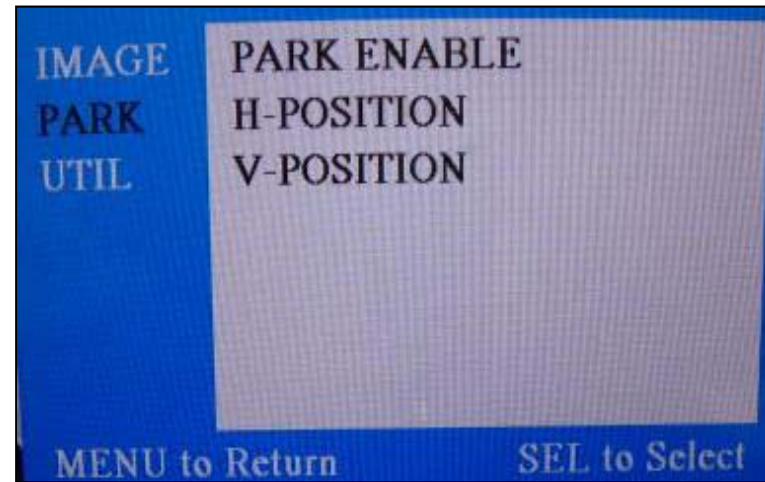
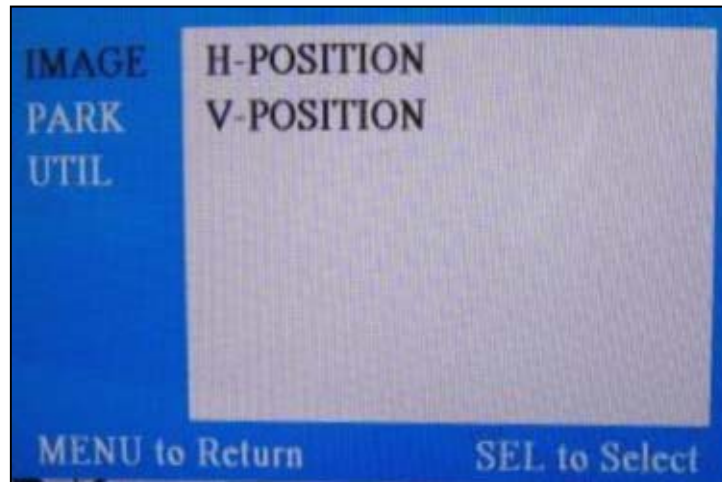

Factory Mode

- IMAGE - H-POSITION : Move to Left, Right
 - V-POSITION : Move to Up, Down
- PARK - PARK ENABLE : Setting to use 'Parking guide line'
 - H-POSITION : Move the lines to Left, Right
 - V-POSITION : Move the lines to Up, Down

OSD(On Screen Display)



• Factory Mode

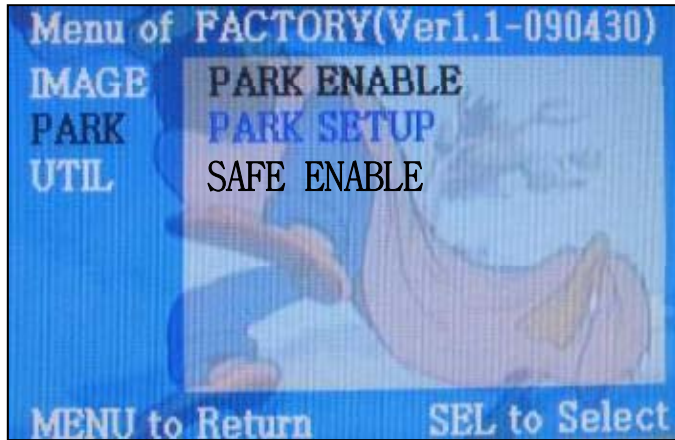

Factory Mode :

-**PARK** PARK ENABLE : Refer to next page

SAFE ENABLE : In case of Connecting "Safe" wire from the power cable to the hand break,

ENABLE – OEM Picture displays in Drive gear position

DISABLE – No display locked in any gear position

- **UTIL** NAVI MODEL : DEFAULTL
 KD680-NEW (For China)
 REXTA (For Korea)
 MD7000 (For Korea)

FACTORY RESET

-Factory Mode : Parking Guide Line



Factory Default : PARK ENABLE – OFF



① Set "PARK ENABLE" to "ON" on
The park mode like the left
picture no.1

*** If you would like to remove this
line, just select "OFF" on the
above process.**



② After setting, once you put the
gear to rear, the screen displays
the parking guide line like the
left picture no. 2.

-Factory Mode : Parking Guide Line



③



③ The way to move the lines

: Once you operate “*Factory Mode” again, when the lines are appeared, OSD image will be displayed like the left picture no.3

After that, you select “PARK” and can move the lines by ‘UP’;‘DOWN’ keys of keypad.

H-POSITION: Move to Left, Right

V-POSITION: Move to Up, Down

- Factory Mode - Operated by pressing ▲ → ▼ → ▲ →MENU or press ◀ more than 5sec of remote

Product Composition



Power Cable: 1 EA

A/V Cable : 1 EA

IR Cable : 1 EA

Remote Control : 1 EA

LCD Out Cable : 1 EA

NAVI Cable : 1 EA

Toggle S/W : 1EA

Sel Out : 1EA

Installation Structure

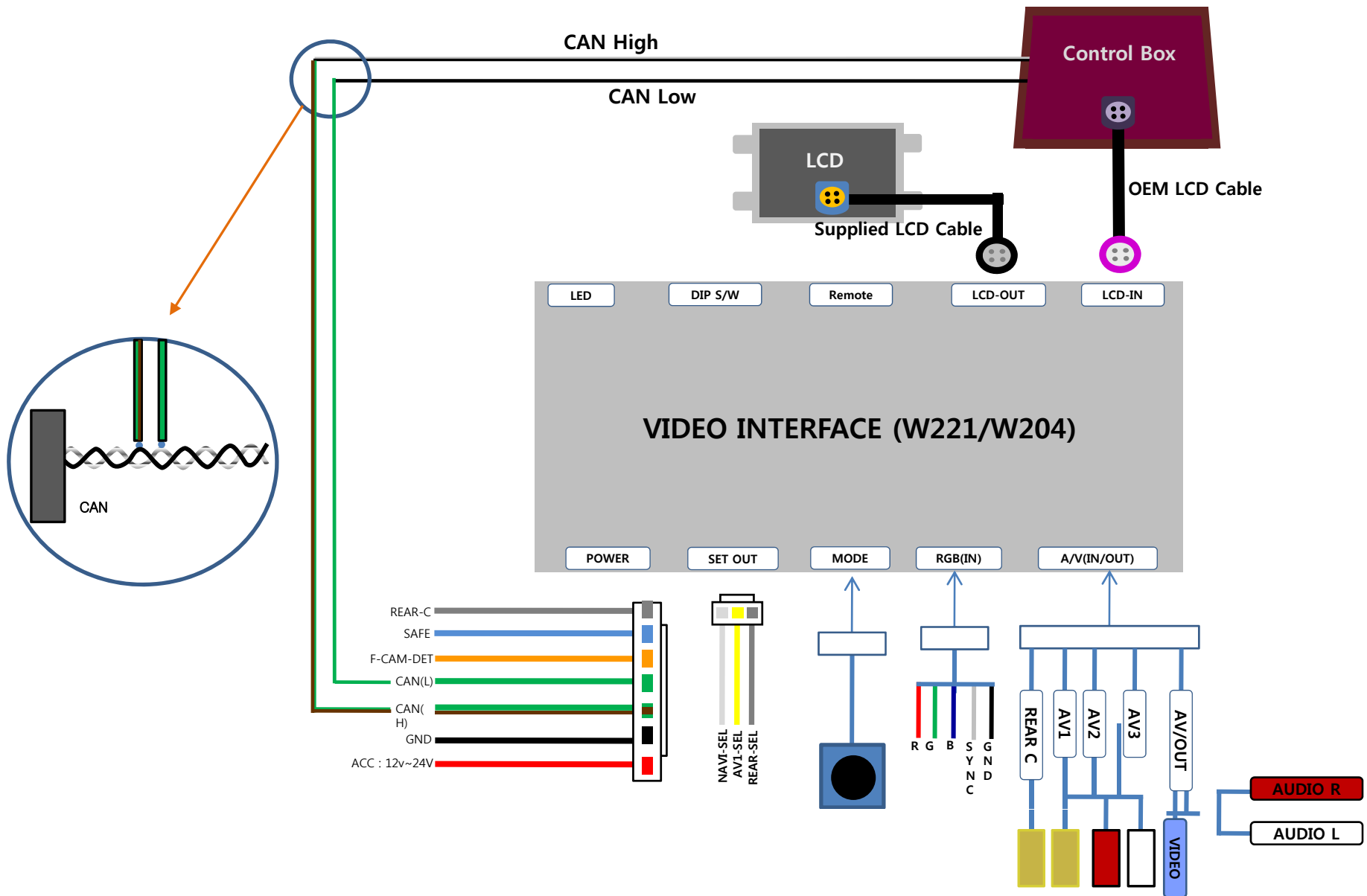

Installation Guide



1. Glove Box Disassembly



As above pictures, with a proper tools disassemble the air-con cover after removing screws on the driver's seat and passenger's seat sides.

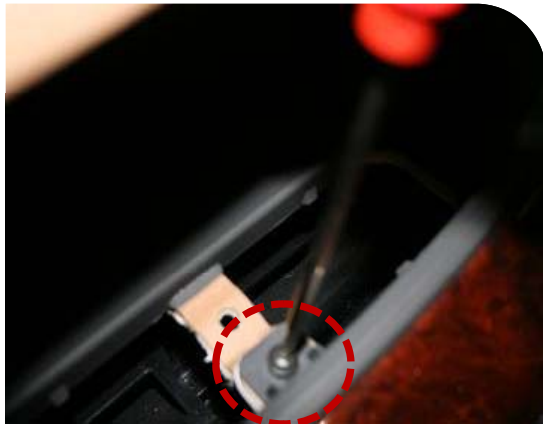

As above pictures, pull and take apart the glove box with hands after removing screws.

Installation Guide



2. Monitor Disassembly



After removing the protection cover with a proper tool, unscrew the screws and pull and take apart left side of LCD.



Disassemble the monitor with unscrewing the screws highlighted in red as above pictures.

Installation Guide



3. CUP Holder and HEAD UNIT Disassembly (DVD Control Box)



Take apart a CUP Holder

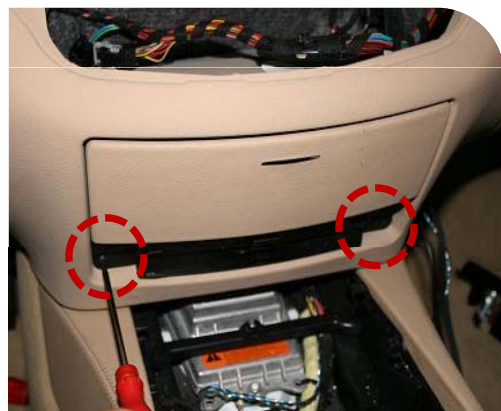

Disassemble DVD cover and Head Unit



Installation Guide



4. CAN and LCD cable Connection



Connect supplied CAN wires to CAN wires from Car
-White + Black : CAN High
Black : CAN LOW

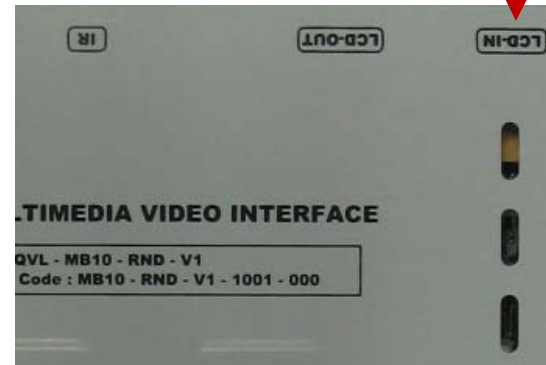

Connect OEM LCD cable into LCD-IN input of the interface board and supplied LCD-Out cable into the OEM Monitor.

-FAQ



1. When can not change mode.
 - Check if the IR Cable (remote control) is connected or not.
 - Check if LED is turned on or not. If it is not turned on, Check if power cable is connected or not.
 - Check if CAN is connected well.

2. When the screen is displaying only black color.
 - Check if 2nd LED is turned on or not. If it is not turned on, please check all video sources that you will connect with the interface is operating well or not.
 - Check if interface is connected well.

3. When displayed color of screen is not proper. (If it's too dark or the color is not proper)
 - Try to push "Reset button" on the remote control. If the color of screen keeps on displaying wrong color, you have to ask manufacturer for the problem.
 - Try to adjust Color, Contrast, Brightness by the remote.

4. When Back-up camera is not displayed on the screen.
 - Turn Dip S/W no.7 on.

5. When the mode you set is not skip.
 - Check if Dip S/W is set in proper way.

6. When Main screen on the car is not displayed.
 - Check if In/Out cables are connected well. If it keeps showing the same problem, you have to ask manufacturer for the problem.

7. When the screen is displaying only white color.
 - Check if out cable is connected well. If it keeps showing the same problem, you have to ask manufacturer for the problem.